

CS-4510ES_Y45L

Published:07/25/2018

TABLE OF CONTENTS

CYLINDER, PISTON, CRANKSHAFT.....	1
ENGINE COVER.....	3
MAGNETO.....	5
AIR CLEANER, CARBURETOR.....	7
CARBURETOR.....	9
MUFFLER.....	11
RECOIL STARTER.....	13
HANDLE.....	15
CHAIN BRAKE.....	17
ACCESSORIES.....	19
OILER.....	21
GUIDE BAR, CHAIN.....	23
OPTION PARTS.....	25

CYLINDER, PISTON, CRANKSHAFT

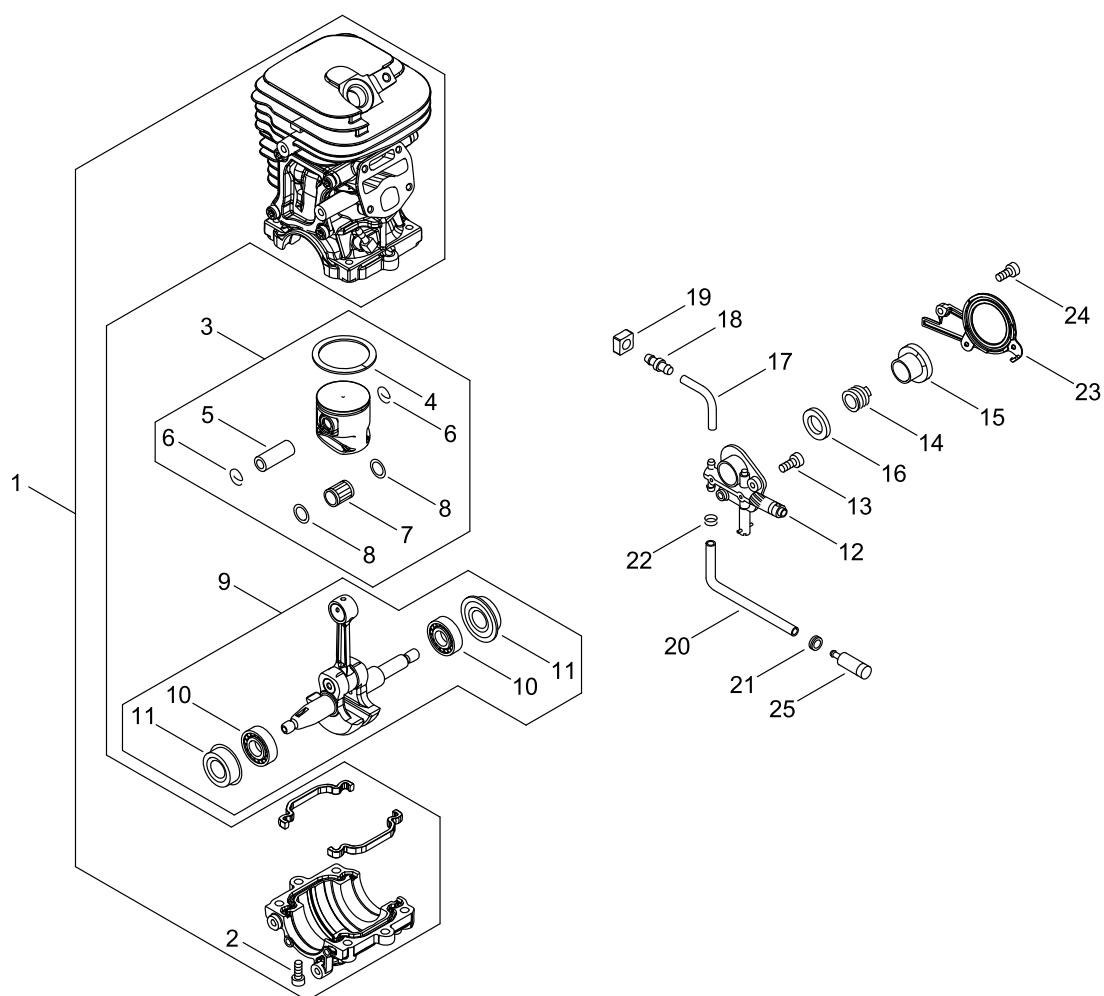

CYLINDER, PISTON, CRANKSHAFT

KEY NO	LV(+)	Part No	Description	Qty	Standard	Comment
1		P100-004570	CRANKCASE SET	1		
2	+	V805-000250	BOLT, TORX 5	2	TB-5*16 12.9	
3		P100-004580	PISTON KIT	1		
4	+	A101-000710	RING, PISTON	1	Φ 43*1.5*1.8	
5	+	100013-39730	PIN, PISTON	1		
6	+	V580-000010	RING,END	2	10	
7	+	V555-000140	BEARING,NEEDLE	1		
8	+	100014-17330	SPACER, PISTON PIN	2		
9		P100-004590	CRANKSHAFT ASY	1		
10	+	900810-36202	BEARING, BALL 6202	2	6202/C3	
11	+	V508-000110	SEAL,OIL 15	2		
12		C022-000010	OILER,ASM AUTO	1		
13		V805-000140	BOLT, TORX 5	2	TB-5*12 10.9	
14		V652-000030	GEAR,WORM	1		
15		V356-000390	COLLAR,10	1		
16		V308-000030	WASHER,CIRCULAR 11	1	10.5*17.4*1.8	
17		V471-005190	PIPE	1	3*6*49	
18		V187-000010	NIPPLE	1		
19		A203-000090	SEAL	1		
20		V471-005200	PIPE	1	3*6*200	
21		132115-01461	GROMMET	1		
22		V490-001230	CLIP	1		
23		C236-000160	COVER,OILER	1		
24		V804-000000	BOLT, TORX 4	1	TT-4*12 DG 10.9	
25		P100-001900	STRAINER, OIL	1		

ENGINE COVER

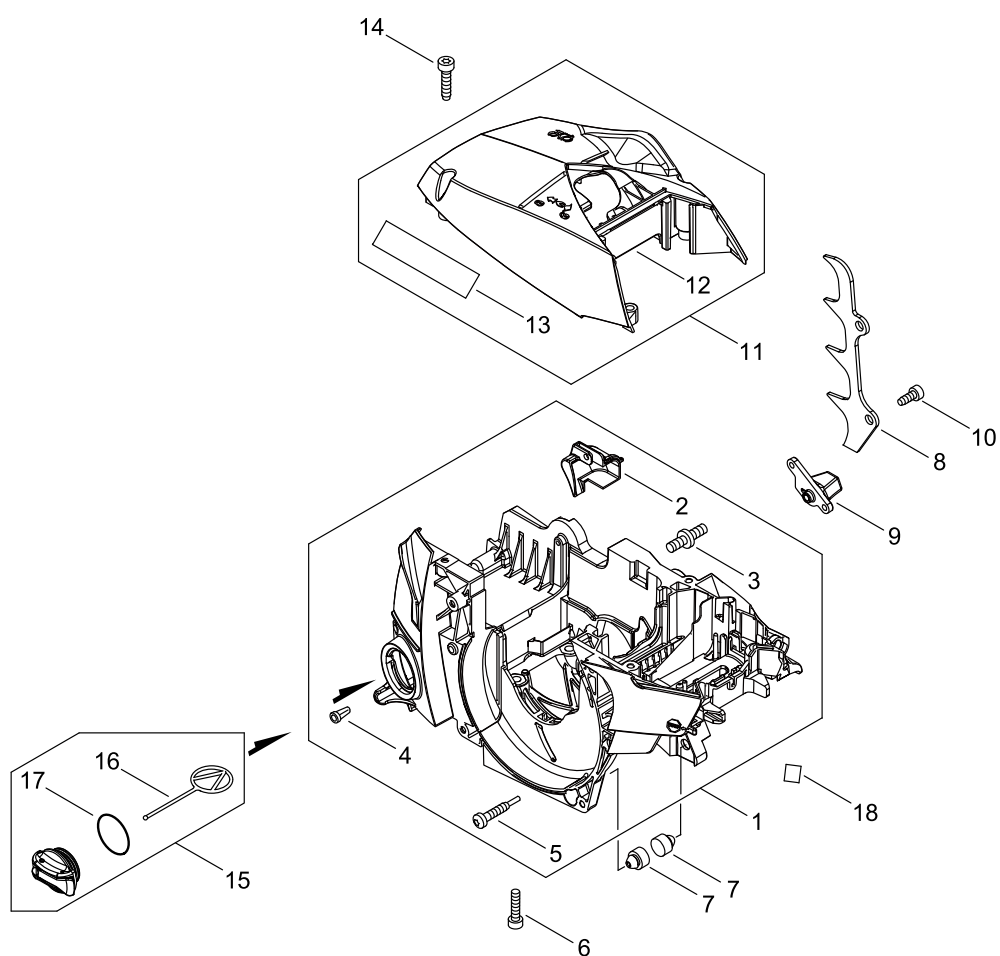

ENGINE COVER

KEY NO	LV(+)	Part No	Description	Qty	Standard	Comment
1		P100-004600	COVER ENGINE ASY	1		
2	+	A161-000370	DUCT, AIR	1		
3	+	V225-000370	BOLT,STUD 8	2	M8	
4	+	436114-13930	VALVE, CHECK	1		
5	+	V203-002380	BOLT,5	1	STOPPER BOLT	
6		V805-000270	BOLT, TORX 5	4	TB-5*40 12.9	
7		V420-001790	CUSHION	2		
8		C304-000330	SPIKED	1		
9		C310-000150	CATCHER, CHAIN	1		
10		V805-000010	BOLT, TORX 5	3	TT-5*20 DG 10.9	
11		A160-003360	COVER,CYLINDER	1	LABEL	
12	+	A160-003430	COVER,CYLINDER	1		
13	+	X502-001060	LABEL,ECHO	1		
14		V805-000010	BOLT, TORX 5	3	TT-5*20 DG 10.9	
15		P100-004610	CAP,OIL ASY	1		
16	+	A365-000050	CONNECTOR,CAP	1		
17	+	900720-20029	O-RING 29	1	P-29	
18		X510-001050	LABEL,SWITCH	1		

MAGNETO

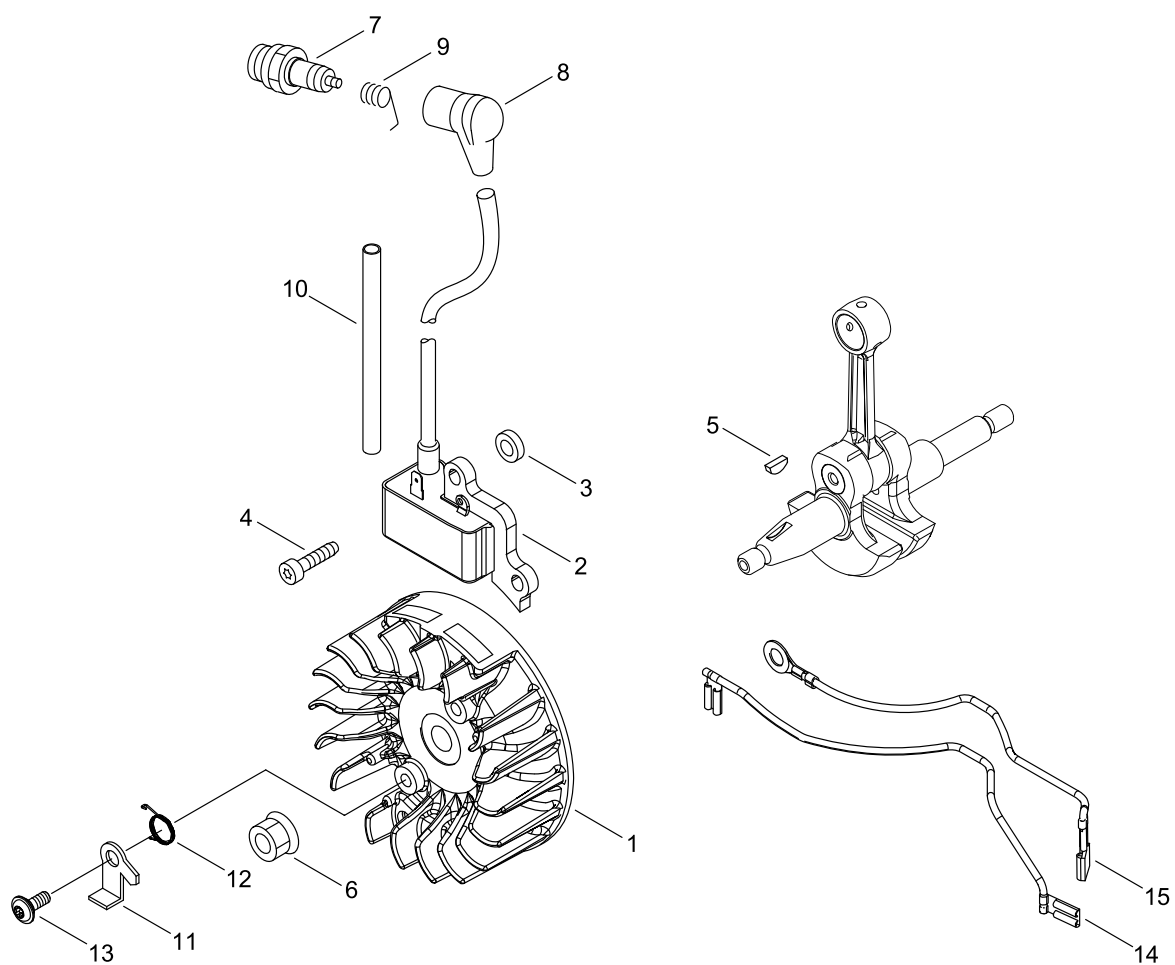

MAGNETO

KEY NO	LV(+)	Part No	Description	Qty	Standard	Comment
1		A409-001330	ROTOR, MAGNETO	1	ID#*****	
2		A411-001740	COIL, IGNITION	1	ID#*****	
3		150117-16430	SPACER	2		
4		V805-000210	BOLT, TORX 5	2	TB-5*20 12.9	
5		100142-12330	KEY, WOODRUFF	1		
6		900515-00008	NUT, FLANGE 8	1	8	
7		A425-000000	SPARKPLUG	1	BPMR8Y	
8		A427-000190	CAP,SPARK PLUG	1		
9		A426-000010	TERMINAL,SPARKPLUG	1		
10		V475-009180	TUBE	1	SSG-1 6*7.2*100	
11		A514-000050	PAWL	2		
12		177234-35430	SPRING, RETURN	2		
13		V203-002250	BOLT,5	2		
14		V485-002960	LEAD	1	L155	
15		V485-002970	LEAD	1	L153	

AIR CLEANER, CARBURETOR

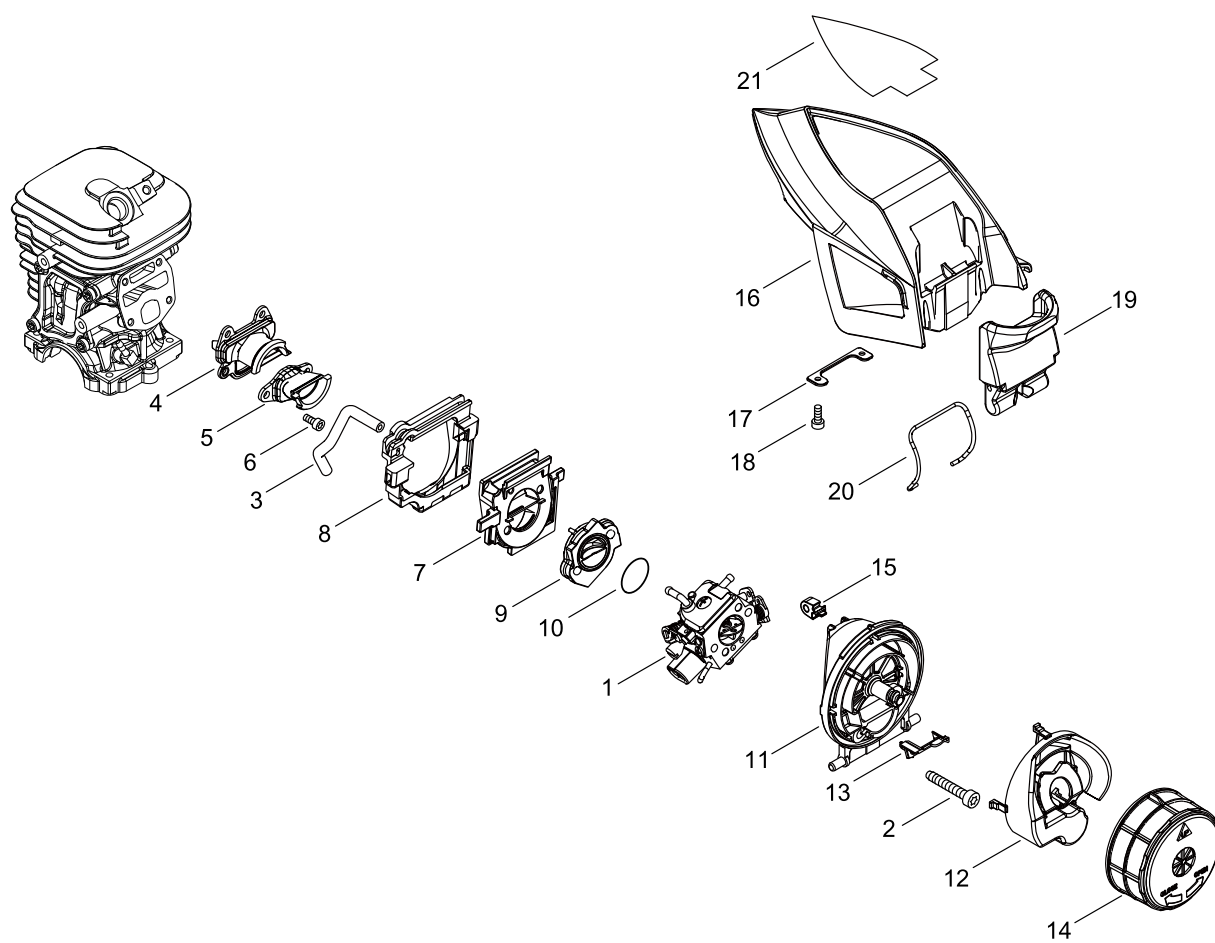

AIR CLEANER, CARBURETOR

KEY NO	LV(+)	Part No	Description	Qty	Standard	Comment
1		A021-004810	CARBURETOR, DIAPHRAGM	1		
2		V805-000040	BOLT, TORX 5	2	TT-5*55 DG 10.9	
3		V471-000760	PIPE	1		
4		A202-000310	BELLOWS, INTAKE	1	AIR SIDE	
5		A202-000320	BELLOWS, INTAKE	1	MIX SIDE	
6		V804-000050	BOLT, TORX 4	4	TB-4*12 10.9	
7		A200-001150	INSULATOR, INTAKE	1	CYLINDER SIDE	
8		V420-005250	CUSHION	1	FOR IN- INSULATOR	
9		A200-001160	INSULATOR, INTAKE	1	CARB SIDE	
10		900724-00022	O-RING S-22	1	S-22	
11		A225-000730	CASE,CLEANER	1		
12		A161-000350	DUCT, AIR	1	BIG	
13		A161-000360	DUCT, AIR	1	SMALL	
14		A226-002150	ELEMENT, AIR FILTER	1		
15		V420-005260	CUSHION	1	FOR CLEANERCASE	
16		A232-001940	LID,CLEANER	1		
17		V453-000260	SPRING,FLAT	1	T1.5 1/2H	
18		V804-000000	BOLT, TORX 4	2	TT-4*12 DG 10.9	
19		A235-000440	KNOB,CLEANER LID	1		
20		V582-000280	RING,SNAP	1	O.D. 2	
21		X503-014630	LABEL,MODEL	1	CS-4510ES	

CARBURETOR

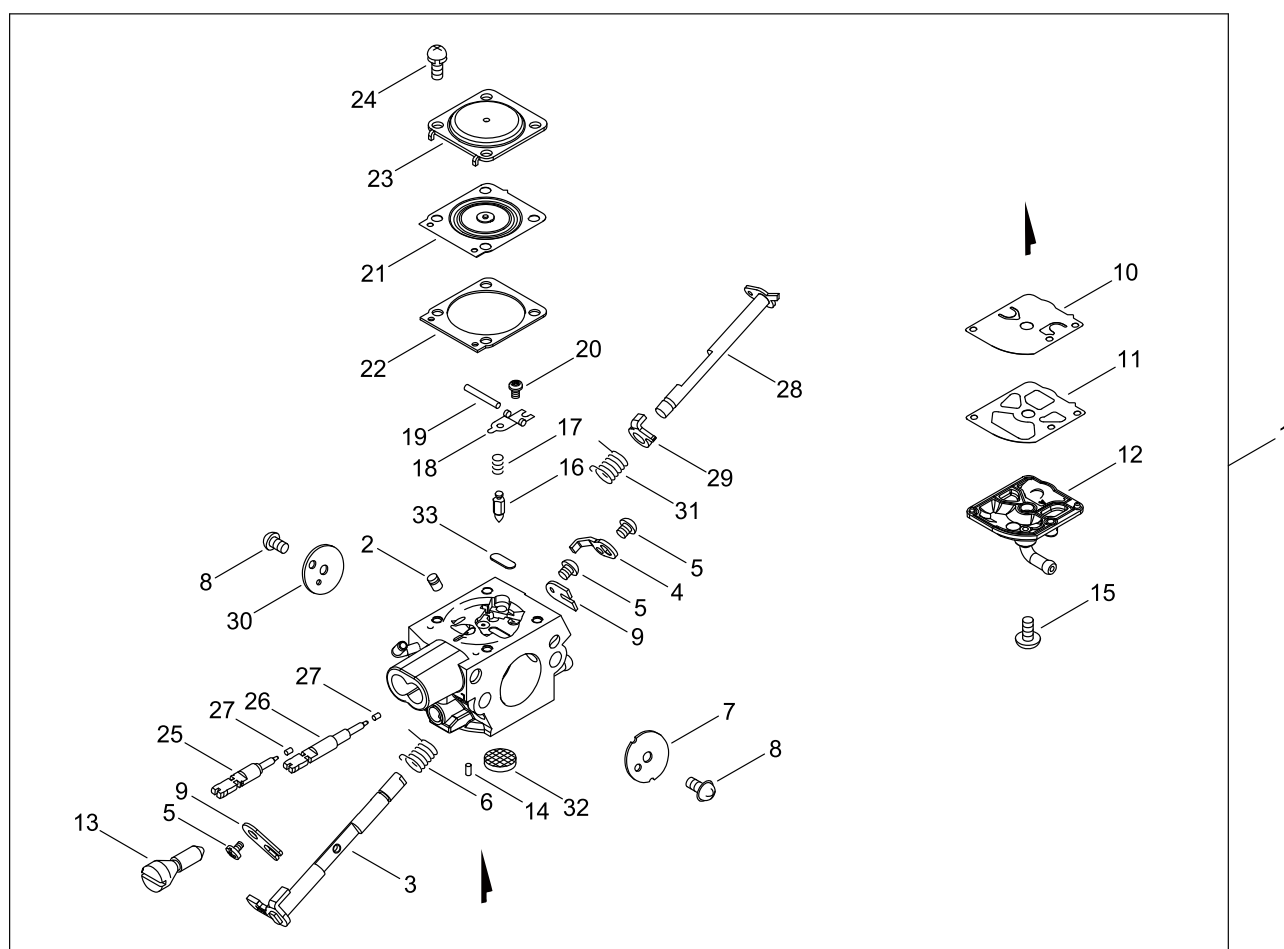

CARBURETOR

KEY NO	LV(+)	Part No	Description	Qty	Standard	Comment
1		A021-004810	CARBURETOR, DIAPHRAGM	1		
2	+	P005-004060	NOZZLE, CHECK VALVE	1		
3	+	P005-004070	SHAFT ASY, THROTTLE	1		
4	+	P005-004080	LEVER, THROTTLE	1		
5	+	125348-13930	SCREW	3		
6	+	P005-004090	SPRING, RETURN	1		
7	+	P005-004100	VALVE, THROTTLE	1		
8	+	125314-51230	SCREW	2	3*4.5	
9	+	P005-003820	RETAINER, SHAFT	2		
10	+	P005-001110	DIAPHRAGM, PUMP	1		
11	+	125325-08360	GASKET, PUMP	1		
12	+	P005-004110	COVER, PUMP	1		
13	+	P005-004120	SCREW, THROTTLEADJUST	1		
14	+	125378-13930	PIECE, FRICTION	1		
15	+	125310-13930	SCREW	1		
16	+	P005-004030	VALVE, INLET NEEDLE	1		
17	+	125322-13930	SPRING, COIL	1		
18	+	125323-08260	ARM, VALVE	1		
19	+	125338-13930	PIN, METERING ARM	1		
20	+	P005-004130	SCREW	1		
21	+	P005-003190	DIAPHRAGM ,METERING	1		
22	+	P005-003200	GASKET, METERING	1		
23	+	P005-003210	COVER, METERING	1		
24	+	P005-003840	SCREW	4		
25	+	P005-004160	SCREW, MAIN MIXTURE	1		
26	+	P005-004170	SCREW, IDLE MIXTURE	1		
27	+	125363-12820	RETAINER	2		
28	+	P005-004180	SHAFT, CHOKE ASY	1		
29	+	P005-004190	LEVER, CHOKE	1		
30	+	P005-004200	VALVE, CHOKE	1		
31	+	P005-004210	SPRING, RETURN	1		
32	+	P005-000860	SCREEN, FUEL INLET	1		
33	+	P005-000410	PLUG, WELCH	1		

MUFFLER

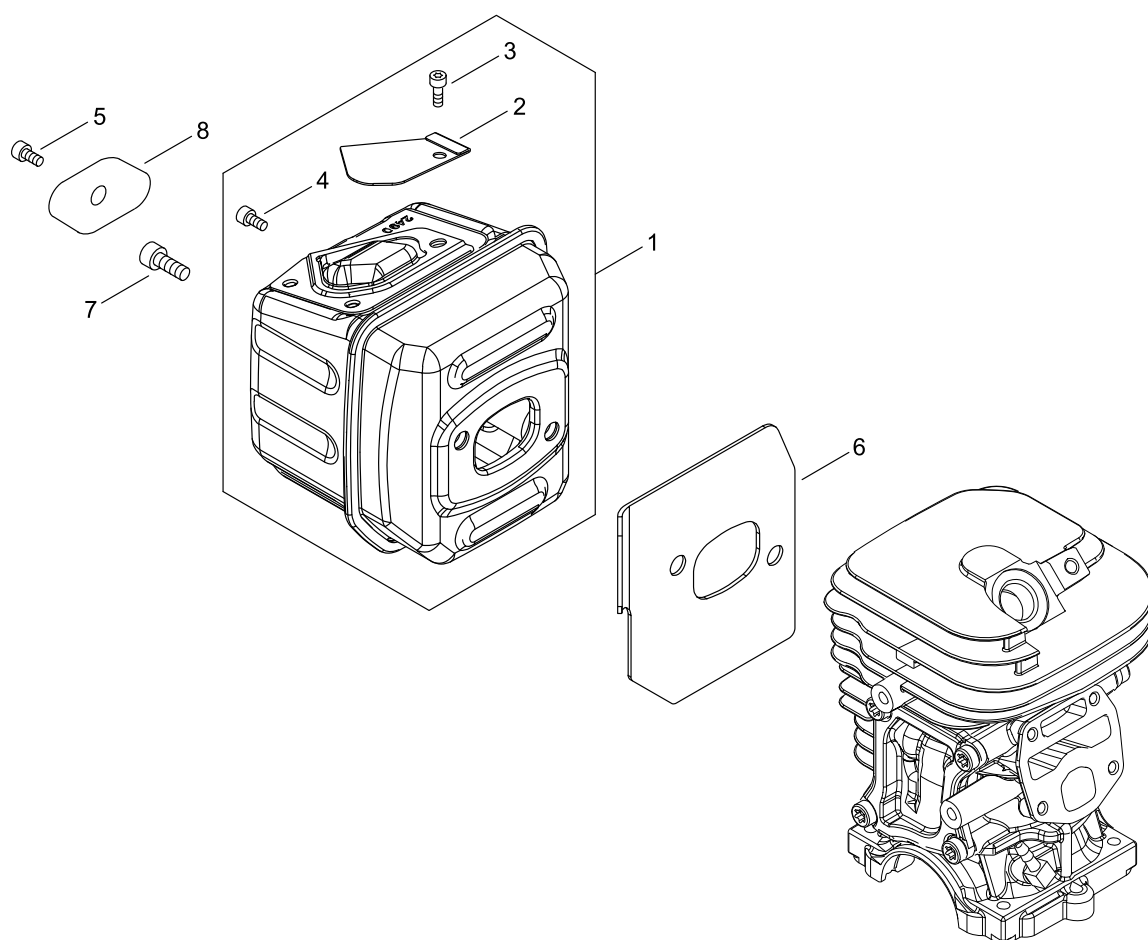

MUFFLER

KEY NO	LV(+)	Part No	Description	Qty	Standard	Comment
1		P100-004620	MUFFLER ASY	1		
2	+	A310-000500	SCREEN, ARRESTOR	1		
3	+	V804-000030	BOLT, TORX 4	1	TB-4*8 10.9	
4	+	V804-000030	BOLT, TORX 4	1	TB-4*8 10.9	
5		V804-000030	BOLT, TORX 4	1	TB-4*8 10.9	
6		V104-002340	GASKET,EXHAUST	1	T:1.0	
7		V805-000250	BOLT, TORX 5	2	TB-5*16 12.9	
8		145711-60631	STAY, MUFFLER	1		

RECOIL STARTER

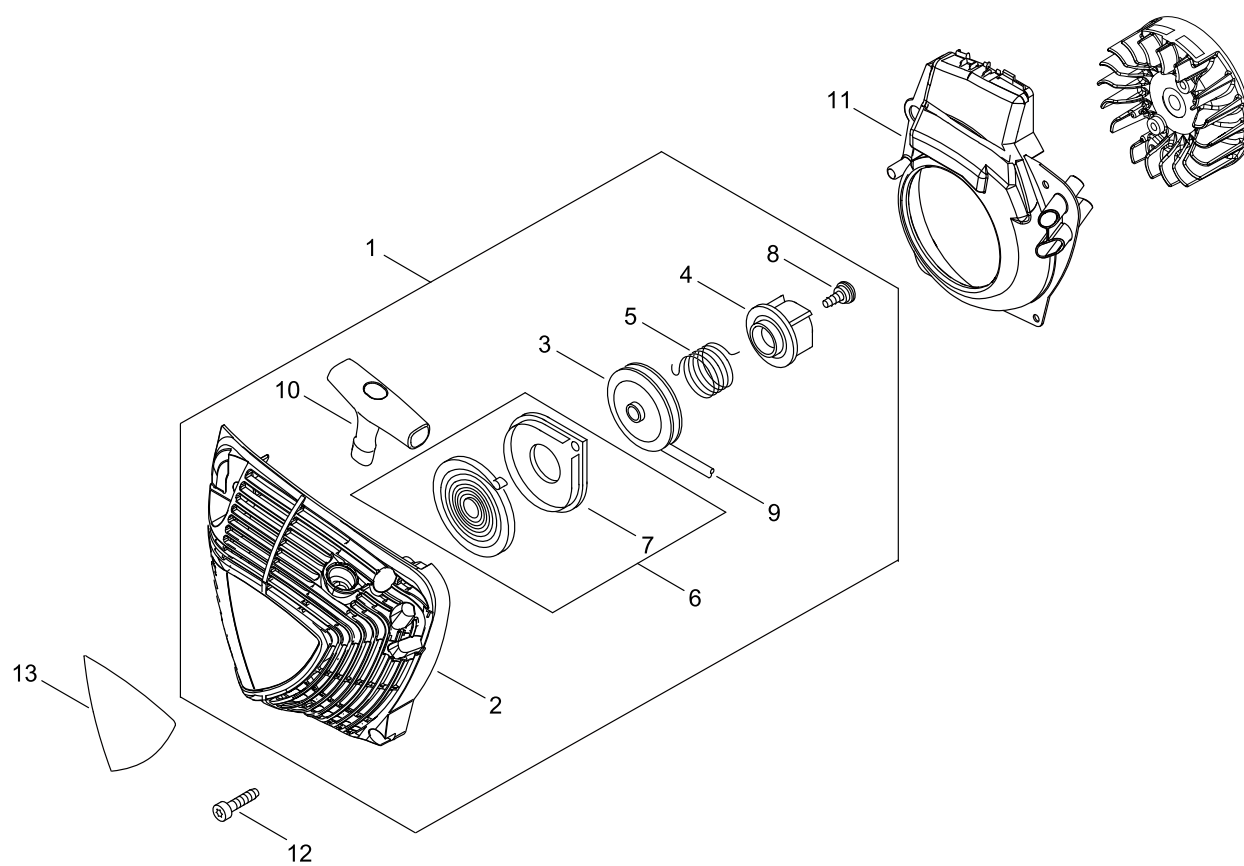

RECOIL STARTER

KEY NO	LV(+)	Part No	Description	Qty	Standard	Comment
1		A051-003300	STARTER,RECOIL ASY	1	SI	
2	+	P022-050400	STARTER CASE	1		
3	+	P022-050410	DRUM, STARTER	1		
4	+	P022-050430	PLATE, CAM	1		
5	+	P022-050420	SPRING,DAMPER	1		
6	+	P022-001330	SPRING KIT, REWIND	1		
7	++	P022-033280	SPRING CASE	1		
8	+	177236-61830	SCREW	1		
9	+	P022-050440	ROPE, STARTER	1		
10	+	P022-050450	GRIP, STARTER	1		
11		A172-003290	COVER,FAN	1		
12		V805-000010	BOLT, TORX 5	3	TT-5*20 DG 10.9	
13		X503-014430	LABEL,MODEL	1	CS-4510ES	

HANDLE

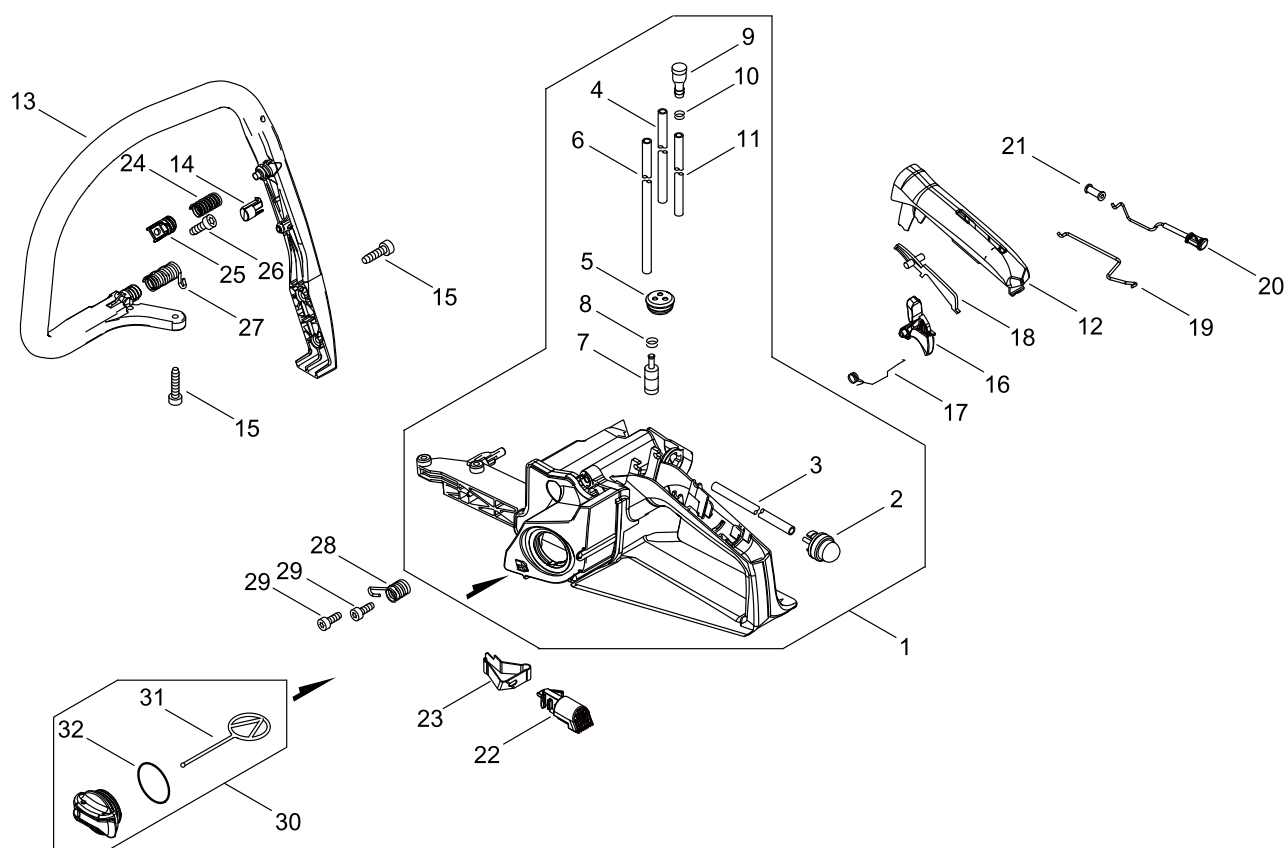

HANDLE

KEY NO	LV(+)	Part No	Description	Qty	Standard	Comment
1		P100-004630	REAR HANDLE ASY	1		
2	+	123181-39130	PUMP, PRIMER	1		
3	+	V471-005210	PIPE	1	2.4*5*165	
4	+	V471-001290	PIPE	1	2.4*5*75	
5	+	132115-55930	GROMMET, FUEL	1		
6	+	V471-005180	PIPE	1	3*5*300	
7	+	A369-000420	STRAINER, FUEL	1	ES-16499	
8	+	V490-001240	CLIP	1		
9	+	131300-56431	VENT ASSEMBLY, FUEL	1		
10	+	V490-001230	CLIP	1		
11	+	V471-005190	PIPE	1	3*6*49	
12		C411-000230	LID,HANDLE	1		
13		C400-001630	HANDLE, FRONT	1	GAI	
14		V420-005270	CUSHION	1	FOR FRONT HANDLE	
15		V805-000010	BOLT, TORX 5	4	TT-5*20 DG 10.9	
16		C450-001040	CONTROL, THROTTLE	1		
17		V452-000260	SPRING,TORSION	1		
18		178090-37930	LOCKOUT, T. CONTROL	1		
19		C454-000570	ROD, THROTTLE	1		
20		A241-000370	KNOB, CHOKE	1		
21		178810-14534	GROMMET	1		
22		A444-000120	KNOB, SWITCH	1		
23		V486-000540	TERMINAL,LEAD	1		
24		V450-002200	SPRING,COMPRESSION	1	CENTER	
25		V456-000240	HOLDER,SPRING	1		
26		V805-000140	BOLT, TORX 5	1	TB-5*12 10.9	
27		V450-002180	SPRING,COMPRESSION	1	FRONT	
28		V450-002190	SPRING,COMPRESSION	1	REAR TYPE2-A	
29		V805-000240	BOLT, TORX 5	2	TT-5*12 DG 10.9	
30		P100-004640	CAP,FUEL ASY	1		
31	+	A365-000050	CONNECTOR,CAP	1		
32	+	900720-20029	O-RING 29	1	P-29	

CHAIN BRAKE

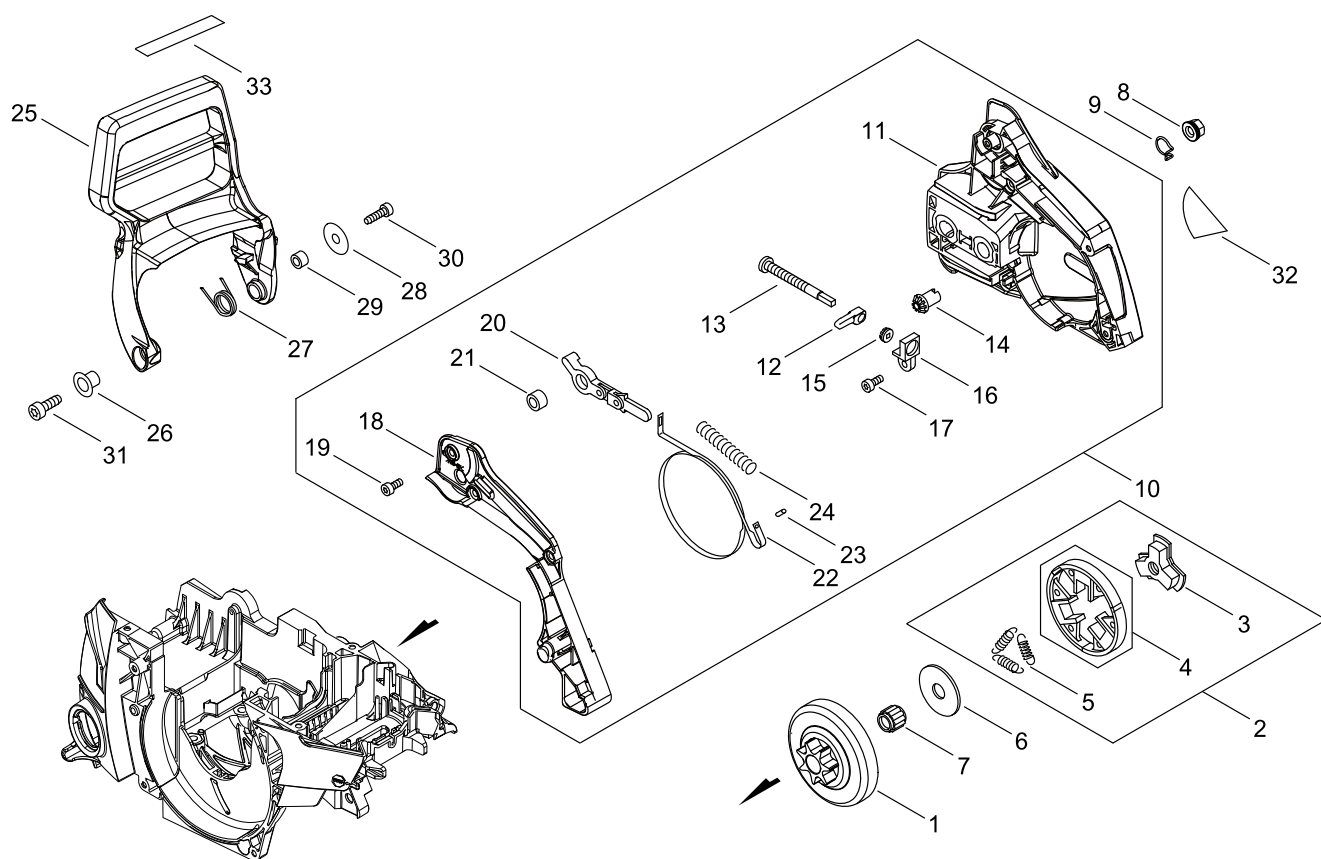

CHAIN BRAKE

KEY NO	LV(+)	Part No	Description	Qty	Standard	Comment
1		A556-000481	DRUM, CLUTCH	1		
2		A056-000840	CLUTCH ASY	1		
3	+	A552-000470	HUB, CLUTCH	1		
4	+	P021-007051	CLUTCH SHOE SET	1		
5	+	V451-000500	SPRING,TENSION	3		
6		175019-39430	PLATE, CLUTCH	1		
7		V555-000170	BEARING,NEEDLE 10	1	8E- KV10*13*12.8	
8		V265-000550	NUT,8	2		
9		C649-000420	HOOK	2		
10		P100-004651	GUARD, SPROCKET ASY	1		
11	+	C300-001161	GUARD, SPROCKET	1		
12	+	C309-000070	TENSIONER, CHAIN	1		
13	+	V203-000110	BOLT,5	1		
14	+	V651-001040	GEAR,BEVEL	1		
15	+	V651-001050	GEAR,BEVEL	1		
16	+	V355-000140	COLLAR,8	1		
17	+	V804-000010	BOLT, TORX 4	1	TT-4*16 DG 10.9	
18	+	C345-000651	COVER,BRAKE	1		
19	+	V804-000010	BOLT, TORX 4	4	TT-4*16 DG 10.9	
20	+	C334-000100	CONNECTOR, BRAKE	1		
21	+	433116-35430	SPACER 8	1	8*12*9	
22	+	C328-000110	BAND, BRAKE	1		
23	+	900330-30120	PIN	1	3*12	
24	+	V450-000070	SPRING,COMPRESSION	1		
25		C320-000530	LEVER, BRAKE	1		
26		V356-000430	COLLAR,10	1		
27		V452-001281	SPRING,TORSION	1		
28		177214-03930	WASHER	1		
29		433116-35430	SPACER 8	1	8*12*9	
30		V804-000010	BOLT, TORX 4	1	TT-4*16 DG 10.9	
31		V805-000010	BOLT, TORX 5	1	TT-5*20 DG 10.9	
32		X502-001050	LABEL,ECHO	1	D SIDE	
33		X505-010150	LABEL,CAUTION	1	CE CAUTION	

ACCESSORIES

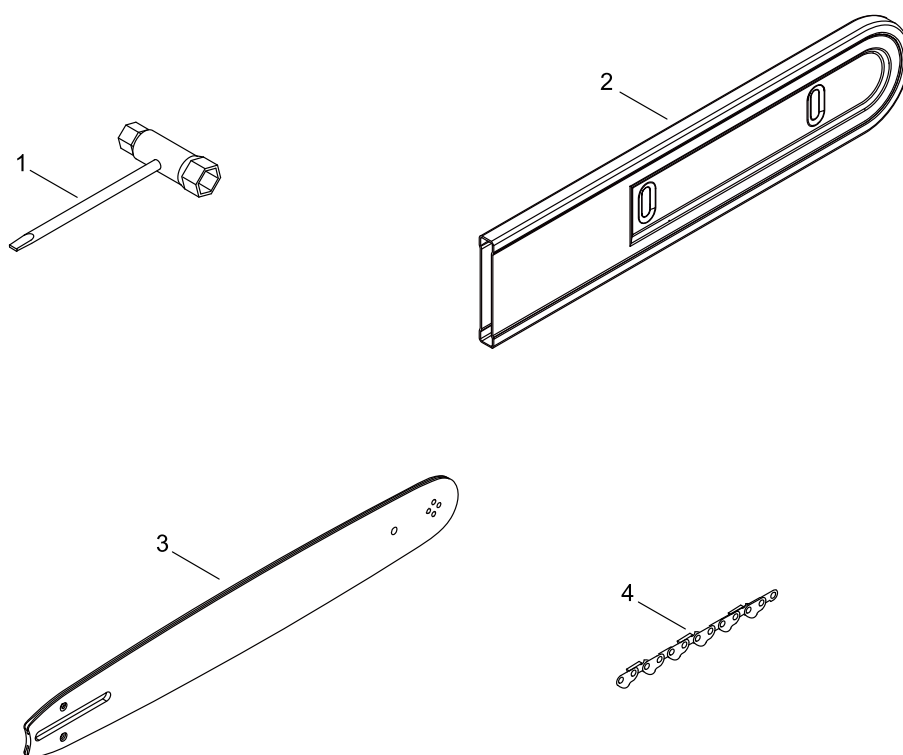

ACCESSORIES

KEY NO	LV(+)	Part No	Description	Qty	Standard	Comment
1		X602-000080	TOOL,WRENCH	1	13*19 L180	
2		X490-000490	SCABBARD,CHAIN	1		
3		X125-000390	BAR,GUIDE 45	1	Y45S21-72ML- ED	
4		431717-30231	CHAIN, SAW	1	21BPX-72E	

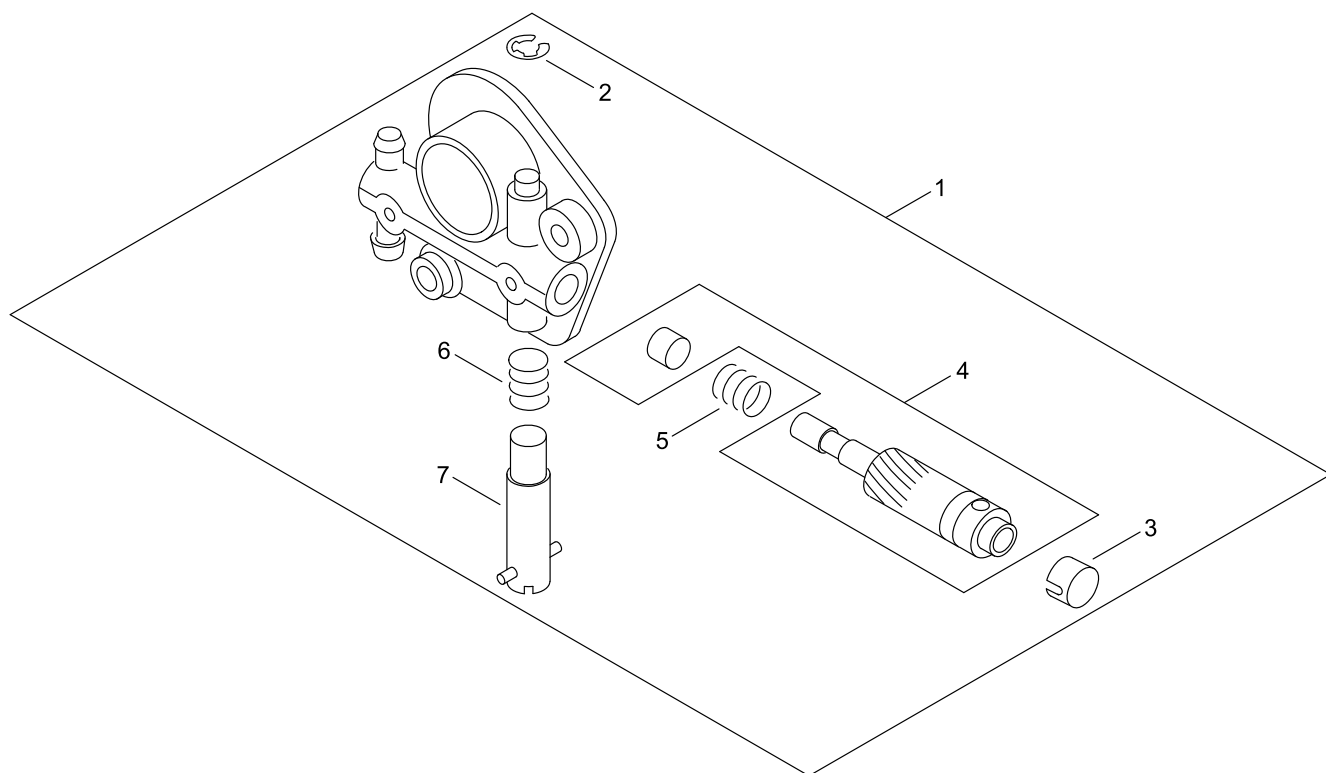

OILER



OILER

KEY NO	LV(+)	Part No	Description	Qty	Standard	Comment
1		C022-000010	OILER,ASM AUTO	1		
2	+	125327-15130	CLIP	1		
3	+	P022-010640	CAP, OIL PUMP	1		
4	+	P022-010650	PLUNGER	1		
5	+	P022-010660	SPRING	1		
6	+	P022-010670	SPRING	1		
7	+	P022-010680	SCREW ASS'Y, ADJUST	1		

GUIDE BAR, CHAIN

Pitch ピッチ	Gauge ゲージ	Length 長さ	Guide Bar ガイドバー		Saw Chain ソーチェン		Hard Nose ハード ノーズ 	Sprocket Nose スプロケット ノーズ 
			Key	Type 形式	Key	Type 形式		
.325 8.26	0.058 1.47	33	A1	Y33S21-56ML- ED	A2	21BPX-56E		●
.325 8.26	0.058 1.47	38	B1	Y38S21-64ML- ED	B2	21BPX-64E		●
.325 8.26	0.058 1.47	45	C1	Y45S21-72ML- ED	C2	21BPX-72E		●
.325 8.26	0.058 1.47	50	D1	Y50S21-80AL- ED	D2	21BPX-80E		●
.325 8.26	0.058 1.47	38	E1	Y38R21-64AA- ET	E2	21BPX-64E		●
.325 8.26	0.058 1.47	45	F1	Y45R21-72AA- ET	F2	21BPX-72E		●
.325 8.26	0.058 1.47	50	G1	Y50R21-80AA- ET	G2	21BPX-80E		●

GUIDE BAR, CHAIN

KEY NO	LV(+)	Part No	Description	Qty	Standard	Comment
A1		X122-000390	BAR,GUIDE 30	1	Y33S21-56ML-ED	
A2		431713-30231	CHAIN, SAW 21BPX-56E	1	21BPX-56E	
B1		X123-000620	BAR,GUIDE 35	1	Y38S21-64ML-ED	
B2		431721-30231	CHAIN, SAW	1	21BPX-64E	
C1		X125-000390	BAR,GUIDE 45	1	Y45S21-72ML-ED	
C2		431717-30231	CHAIN, SAW	1	21BPX-72E	
D1		X126-000300	BAR,GUIDE 50	1	Y50S21-80AL-ED	
D2		431712-30231	CHAIN, SAW	1	21BPX-80E	
E1		X123-000650	BAR,GUIDE 35	1	Y38R21-64AA-ET	
E2		431721-30231	CHAIN, SAW	1	21BPX-64E	
F1		X125-000420	BAR,GUIDE 45	1	Y45R21-72AA-ET	
F2		431717-30231	CHAIN, SAW	1	21BPX-72E	
G1		X126-000320	BAR,GUIDE 50	1	Y50R21-80AA-ET	
G2		431712-30231	CHAIN, SAW	1	21BPX-80E	

OPTION PARTS

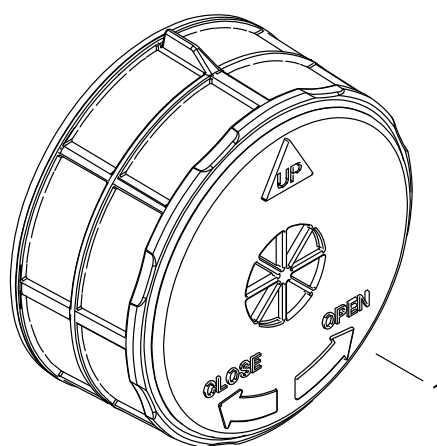

OPTION PARTS

KEY NO	LV(+)	Part No	Description	Qty	Standard	Comment
1		A226-002190	ELEMENT, AIR FILTER	1	OUT/IN:#300/ #80	

NUMERICAL PARTS INDEX

Part No	Part description	Page	Part No	Part description	Page	Part No	Part description	Page
100013-3-9730	PIN, PISTON	2	178810-1-4534	GROMMET	16	A172-00-3290	COVER,FAN	14
100014-1-7330	SPACER, PISTON PIN	2	431712-3-0231	CHAIN, SAW	24	A200-00-1150	INSULATOR, INTAKE	8
100142-1-2330	KEY, WOODRUFF	6	431713-3-0231	CHAIN, SAW 21BPX-56E	24	A200-00-1160	INSULATOR, INTAKE	8
123181-3-9130	PUMP, PRIMER	16	431717-3-0231	CHAIN, SAW	20	A202-00-0310	BELLOWS, INTAKE	8
125310-1-3930	SCREW	10	431717-3-0231	CHAIN, SAW	24	A202-00-0320	BELLOWS, INTAKE	8
125314-5-1230	SCREW	10	431721-3-0231	CHAIN, SAW	24	A203-00-0090	SEAL	2
125322-1-3930	SPRING, COIL	10	433116-3-5430	SPACER 8	18	A225-00-0730	CASE,CLEANER	8
125323-0-8260	ARM, VALVE	10	436114-1-3930	VALVE, CHECK	4	A226-00-2150	ELEMENT, AIR FILTER	8
125325-0-8360	GASKET, PUMP	10	900330-3-0120	PIN	18	A226-00-2190	ELEMENT, AIR FILTER	26
125327-1-5130	CLIP	22	900515-0-0008	NUT, FLANGE 8	6	A232-00-1940	LID,CLEANER	8
125338-1-3930	PIN, METERING ARM	10	900720-2-0029	O-RING 29	4	A235-00-0440	KNOB,CLEANER LID	8
125348-1-3930	SCREW	10	900720-2-0029	O-RING 29	16	A241-00-0370	KNOB, CHOKE	16
125363-1-2820	RETAINER	10	900724-0-0022	O-RING S-22	8	A310-00-0500	SCREEN, ARRESTOR	12
125378-1-3930	PIECE, FRICTION	10	900810-3-6202	BEARING, BALL 6202	2	A365-00-0050	CONNECTOR,CAP	4
131300-5-6431	VENT ASSEMBLY, FUEL	16	A021-00-4810	CARBURETOR, DIAPHRAGM	8	A365-00-0050	CONNECTOR,CAP	16
132115-0-1461	GROMMET	2	A021-00-4810	CARBURETOR, DIAPHRAGM	10	A369-00-0420	STRAINER, FUEL	16
132115-5-5930	GROMMET, FUEL	16	A051-00-3300	STARTER,RECOIL ASY	14	A409-00-1330	ROTOR, MAGNETO	6
145711-6-0631	STAY, MUFFLER	12	A056-00-0840	CLUTCH ASY	18	A411-00-1740	COIL, IGNITION	6
150117-1-6430	SPACER	6	A101-00-0710	RING, PISTON	2	A425-00-0000	SPARKPLUG	6
175019-3-9430	PLATE, CLUTCH	18	A160-00-3360	COVER,CYLINDER	4	A426-00-0010	TERMINAL, SPARKPLUG	6
177214-0-3930	WASHER	18	A160-00-3430	COVER,CYLINDER	4	A427-00-0190	CAP,SPARK PLUG	6
177234-3-5430	SPRING, RETURN	6	A161-00-0350	DUCT, AIR	8	A444-00-0120	KNOB, SWITCH	16
177236-6-1830	SCREW	14	A161-00-0360	DUCT, AIR	8	A514-00-0050	PAWL	6
178090-3-7930	LOCKOUT, T. CONTROL	16	A161-00-0370	DUCT, AIR	4	A552-00-0470	HUB, CLUTCH	18

NUMERICAL PARTS INDEX

Part No	Part description	Page	Part No	Part description	Page	Part No	Part description	Page
A556-00-0481	DRUM, CLUTCH	18	P005-00-3840	SCREW	10	P022-05-0400	STARTER CASE	14
C022-00-0010	OILER,ASM AUTO	2	P005-00-4030	VALVE, INLET NEEDLE	10	P022-05-0410	DRUM, STARTER	14
C022-00-0010	OILER,ASM AUTO	22	P005-00-4060	NOZZLE, CHECK VALVE	10	P022-05-0420	SPRING,DAMPER	14
C236-00-0160	COVER,OILER	2	P005-00-4070	SHAFT ASY, THROTTLE	10	P022-05-0430	PLATE, CAM	14
C300-00-1161	GUARD, SPROCKET	18	P005-00-4080	LEVER, THROTTLE	10	P022-05-0440	ROPE, STARTER	14
C304-00-0330	SPIKED	4	P005-00-4090	SPRING, RETURN	10	P022-05-0450	GRIP, STARTER	14
C309-00-0070	TENSIONER, CHAIN	18	P005-00-4100	VALVE, THROTTLE	10	P100-00-1900	STRAINER, OIL	2
C310-00-0150	CATCHER, CHAIN	4	P005-00-4110	COVER, PUMP	10	P100-00-4570	CRANKCASE SET	2
C320-00-0530	LEVER, BRAKE	18	P005-00-4120	SCREW, THROTTLEADJUST	10	P100-00-4580	PISTON KIT	2
C328-00-0110	BAND, BRAKE	18	P005-00-4130	SCREW	10	P100-00-4590	CRANKSHAFT ASY	2
C334-00-0100	CONNECTOR, BRAKE	18	P005-00-4160	SCREW,MAIN MIXTURE	10	P100-00-4600	COVER ENGINE ASY	4
C345-00-0651	COVER,BRAKE	18	P005-00-4170	SCREW,IDLE MIXTURE	10	P100-00-4610	CAP,OIL ASY	4
C400-00-1630	HANDLE, FRONT	16	P005-00-4180	SHAFT, CHOKE ASY	10	P100-00-4620	MUFFLER ASY	12
C411-00-0230	LID,HANDLE	16	P005-00-4190	LEVER, CHOKE	10	P100-00-4630	REAR HANDLE ASY	16
C450-00-1040	CONTROL, THROTTLE	16	P005-00-4200	VALVE, CHOKE	10	P100-00-4640	CAP,FUEL ASY	16
C454-00-0570	ROD, THROTTLE	16	P005-00-4210	SPRING, RETURN	10	P100-00-4651	GUARD, SPROCKET ASY	18
C649-00-0420	HOOK	18	P021-00-7051	CLUTCH SHOE SET	18	V104-00-2340	GASKET,EXHAUST	12
P005-00-0410	PLUG, WELCH	10	P022-00-1330	SPRING KIT, REWIND	14	V187-00-0010	NIPPLE	2
P005-00-0860	SCREEN, FUEL INLET	10	P022-01-0640	CAP, OIL PUMP	22	V203-00-0110	BOLT,5	18
P005-00-1110	DIAPHRAGM, PUMP	10	P022-01-0650	PLUNGER	22	V203-00-2250	BOLT,5	6
P005-00-3190	DIAPHRAGM , METERING	10	P022-01-0660	SPRING	22	V203-00-2380	BOLT,5	4
P005-00-3200	GASKET, METERING	10	P022-01-0670	SPRING	22	V225-00-0370	BOLT,STUD 8	4
P005-00-3210	COVER, METERING	10	P022-01-0680	SCREW ASS'Y, ADJUST	22	V265-00-0550	NUT,8	18
P005-00-3820	RETAINER, SHAFT	10	P022-03-3280	SPRING CASE	14	V308-00-0030	WASHER,CIRCULAR 11	2

NUMERICAL PARTS INDEX

Part No	Part description	Page	Part No	Part description	Page	Part No	Part description	Page
V355-00-0140	COLLAR,8	18	V485-00-2960	LEAD	6	V805-00-0140	BOLT, TORX 5	2
V356-00-0390	COLLAR,10	2	V485-00-2970	LEAD	6	V805-00-0140	BOLT, TORX 5	16
V356-00-0430	COLLAR,10	18	V486-00-0540	TERMINAL,LEAD	16	V805-00-0210	BOLT, TORX 5	6
V420-00-1790	CUSHION	4	V490-00-1230	CLIP	2	V805-00-0240	BOLT, TORX 5	16
V420-00-5250	CUSHION	8	V490-00-1230	CLIP	16	V805-00-0250	BOLT, TORX 5	2
V420-00-5260	CUSHION	8	V490-00-1240	CLIP	16	V805-00-0250	BOLT, TORX 5	12
V420-00-5270	CUSHION	16	V508-00-0110	SEAL,OIL 15	2	V805-00-0270	BOLT, TORX 5	4
V450-00-0070	SPRING, COMPRESSION	18	V555-00-0140	BEARING,NEEDLE	2	X122-00-0390	BAR,GUIDE 30	24
V450-00-2180	SPRING, COMPRESSION	16	V555-00-0170	BEARING,NEEDLE 10	18	X123-00-0620	BAR,GUIDE 35	24
V450-00-2190	SPRING, COMPRESSION	16	V580-00-0010	RING,END	2	X123-00-0650	BAR,GUIDE 35	24
V450-00-2200	SPRING, COMPRESSION	16	V582-00-0280	RING,SNAP	8	X125-00-0390	BAR,GUIDE 45	20
V451-00-0500	SPRING,TENSION	18	V651-00-1040	GEAR,BEVEL	18	X125-00-0390	BAR,GUIDE 45	24
V452-00-0260	SPRING,TORSION	16	V651-00-1050	GEAR,BEVEL	18	X125-00-0420	BAR,GUIDE 45	24
V452-00-1281	SPRING,TORSION	18	V652-00-0030	GEAR,WORM	2	X126-00-0300	BAR,GUIDE 50	24
V453-00-0260	SPRING,FLAT	8	V804-00-0000	BOLT, TORX 4	2	X126-00-0320	BAR,GUIDE 50	24
V456-00-0240	HOLDER,SPRING	16	V804-00-0000	BOLT, TORX 4	8	X490-00-0490	SCABBARD,CHAIN	20
V471-00-0760	PIPE	8	V804-00-0010	BOLT, TORX 4	18	X502-00-1050	LABEL,ECHO	18
V471-00-1290	PIPE	16	V804-00-0030	BOLT, TORX 4	12	X502-00-1060	LABEL,ECHO	4
V471-00-5180	PIPE	16	V804-00-0050	BOLT, TORX 4	8	X503-01-4430	LABEL,MODEL	14
V471-00-5190	PIPE	2	V805-00-0010	BOLT, TORX 5	4	X503-01-4630	LABEL,MODEL	8
V471-00-5190	PIPE	16	V805-00-0010	BOLT, TORX 5	14	X505-01-0150	LABEL,CAUTION	18
V471-00-5200	PIPE	2	V805-00-0010	BOLT, TORX 5	16	X510-00-1050	LABEL,SWITCH	4
V471-00-5210	PIPE	16	V805-00-0010	BOLT, TORX 5	18	X602-00-0080	TOOL,WRENCH	20
V475-00-9180	TUBE	6	V805-00-0040	BOLT, TORX 5	8			